

HARDIN MARINE 11 Industry Dr. Palm Coast, FL 32137
386-445-2500 / FAX 386-445-1122

PART NO.
620-36001

TITLE:

FORD 460 MANIFOLDS

ITEM NO.	PART NUMBER	DESCRIPTION	QTY.
1	620-36001	MANIFOLD, FORD 460	2
2	90037C500SHS	BOLT, 3/8-16x5.00	16
3	300-1419	GASKET, EXHAUST - FORD 460	2
4	540-222120	FITTING, 3/4NPT x 1" BARB 90 DEG	2

www.hardin-marine.com

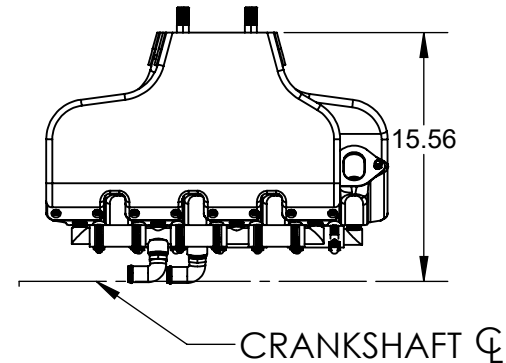
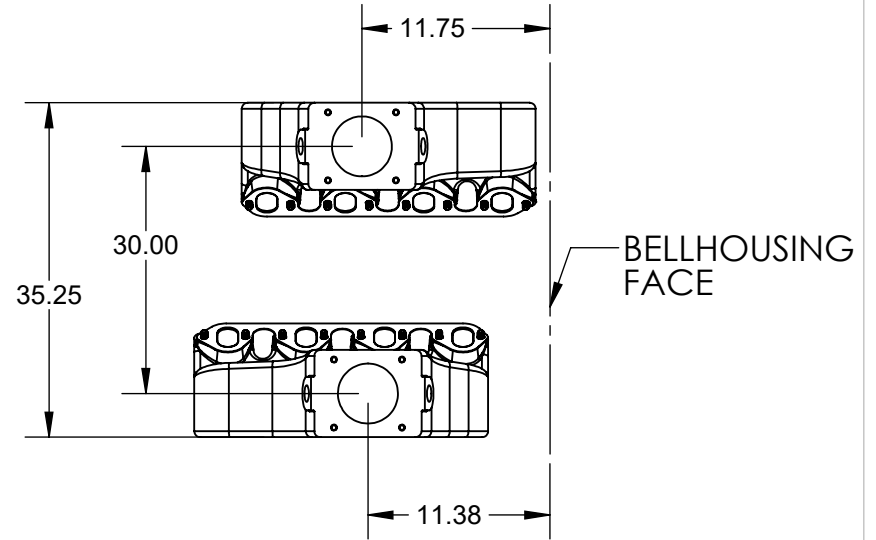
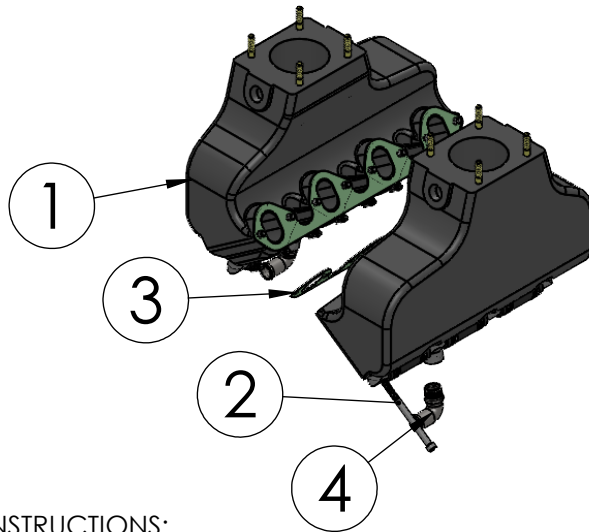

INSTALLATION INSTRUCTIONS:

- 1) MAKE SURE CYLINDER HEAD EXHAUST MOUNTING SURFACE IS FREE OF KNICKS AND ANY OLD GASKET MATERIAL IS REMOVED. SEALANT IS NOT REQUIRED ON THE NEW SUPPLIED GASKETS #3.
- 2) THE PORT AND STARBOARD MANIFOLDS ARE THE SAME PART AND CAN BE USED ON EITHER SIDE OF THE ENGINE #1.
- 3) INSTALL MANIFOLDS WITH THE SUPPLIED 3/8 BOLTS AND WASHERS. APPLY ANTI-SIEZE TO 3/8 MOUNTING BOLTS #3. USING 3/8 12 POINT SOCKET, TORQUE TO 30 FT. LBS..
- 4) APPLY LIQUID TEFLON SEALANT THE SUPPLIED WATER INLET FITTING #4. USING 1-1/16 WRENCH, INSTALL 1" 90 DEGREE HOSE BARB FITTING INTO BOTTOM OF THE MANIFOLD.
- 5) ATTACH 1" WATER INLET HOSE FROM THERMOSTAT HOUSING TO #4 WATER INLET FITTINGS (MAKE SURE IT IS A CONSTANT FLOW WATER SUPPLY).
- 6) GO TO 620-32512 OR 620-32520 TAILPIPE INSTRUCTIONS TO COMPLETE INSTALLATION.

CAUTION HARDIN MARINE MANIFOLD SYSTEMS ARE DESIGNED FOR USE ON ENGINES WITH FULL TIME CONSTANT WATER CIRCULATION AT ALL TIMES. NOTE** AFTER APPROXIMATELY 2-5 HOURS USE OR NUMEROUS ENGINE HEAT CYCLES ALL HARDWARE MUST BE RETORQUED AND OR TIGHTENED.**

THIS DRAWING IS CONFIDENTIAL AND IS SUPPLIED ON EXPRESS CONDITION THAT IT SHALL NOT BE LENT, COPIED OR DISCLOSED TO ANY OTHER PERSON OR USED FOR ANY OTHER PURPOSE WITHOUT WRITTEN CONSENT OF HARDIN MARINE INC.. BREACH OF THIS CONTRACT WILL HOLD AND IT'S PRINCIPALS LIABLE FOR LOSS AND DAMAGES.