

HARDIN  
MARINE

11 Industry Dr. Palm Coast, FL 32137  
386-445-2500 / FAX 386-445-1122

PART NO.  
137-8689/  
137-8690

TITLE:

## #6 3 WIRE CONVERSION

www.hardin-marine.com

ITEM NO.	PART NUMBER	DESCRIPTION	QTY.
1	525-57008	RETAINER	2
2	525-842812	DRIVE, DRIVESHAFT	1
3	525-842814	PIN, #6 HINGE	1
4	525-8M0065246	DRIVESHAFT, SENSOR	1
5	525-8M0095310	SENDER, TRIM 3 WIRE	1
6	90010F075SHS	BOLT, 10-32 x .75	2
7	90010SL-STSS	WASHER, #10	2

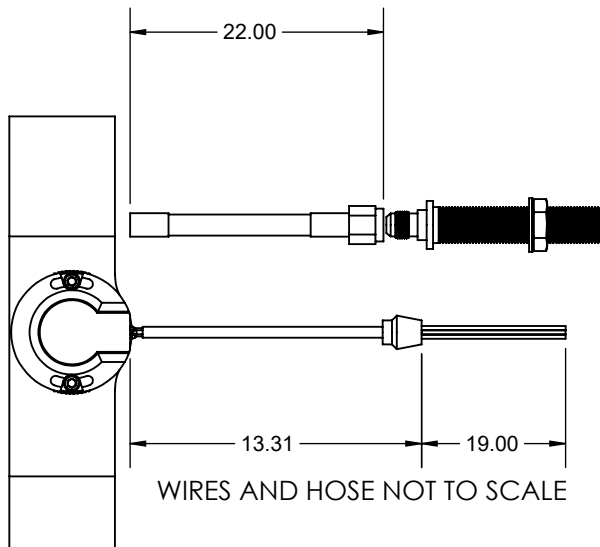
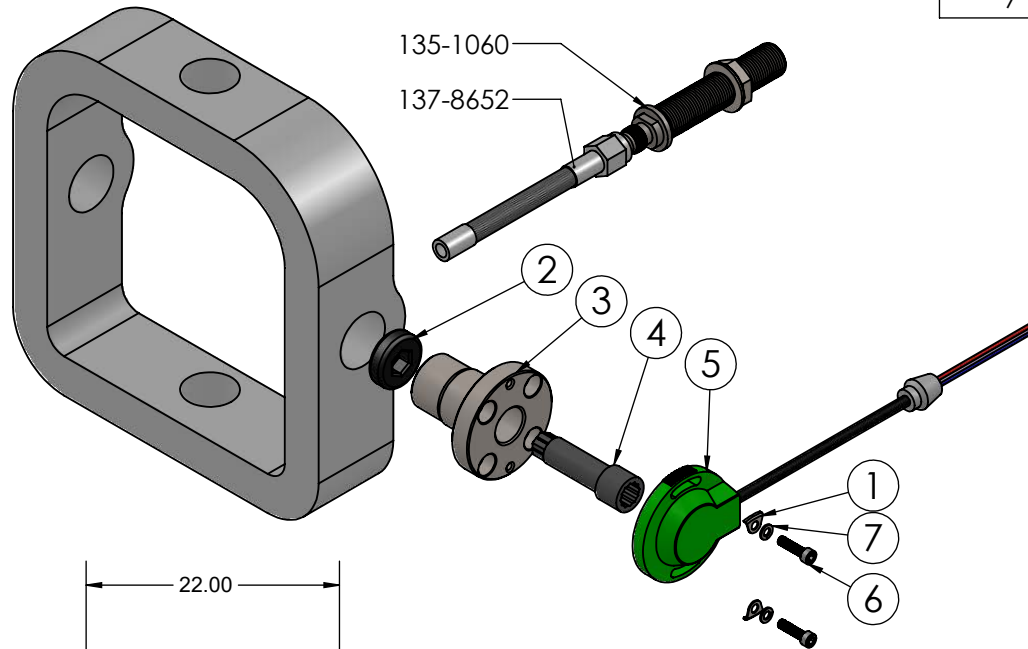

- \* 137-8690 DOES NOT INCLUDE #3 PIN HINGE.
- \* SEE 137-8684 FOR WIRING AND SENDER ADJUSTMENT.
- \* SENDER ROUTING CAN BE THRU THE MERCURY GIMBAL HOUSING OR BY USING OPTIONAL 137-8652 HOSE AND 135-1060 THRU HULL.

THIS DRAWING IS CONFIDENTIAL AND IS SUPPLIED ON EXPRESS CONDITION THAT IT SHALL NOT BE LENT, COPIED OR DISCLOSED TO ANY OTHER PERSON OR USED FOR ANY OTHER PURPOSE WITHOUT WRITTEN CONSENT OF HARDIN MARINE INC.. BREACH OF THIS CONTRACT WILL HOLD ..... AND IT'S PRINCIPALS LIABLE FOR LOSS AND DAMAGES.

HARDIN  
MARINE

11 Industry Dr. Palm Coast, FL 32137  
386-445-2500 / FAX 386-445-1122

PART NO.

137-8684

TITLE:

## 3 WIRE SENDER WIRING

www.hardin-marine.com

DASH PANEL TO 3 WIRE SENDER WIRE COLOR CODE:

- 1) BLACK - GROUND
- 2) RED - 12V/ 5AMP FUSED KEYED POWER
- 3) YELLOW - DASH LIGHTS
- 4) BLUE - PORT SENDER BLUE WIRE
- 5) WHITE - PORT SENDER WHITE WIRE
- 6) GREY - PORT SENDER RED WIRE
- 7) BLUE - STBD SENDER BLUE WIRE
- 8) WHITE - STBD SENDER WHITE WIRE
- 9) GREY - STBD SENDER RED WIRE

**WARNING:**  
ATTACHING POWER TO ANY OTHER WIRE THAN THE RED OR GREY WIRE WILL PERMENANTLY DAMAGE THE SENDER AND DASH PANEL.

USED IN 137-8144, 137-8687, 137-8689, 137-8690 & 137-8729 ACTUATOR KITS

ADJUSTING THE LED LIGHT RANGE FOR MERCURY SMARTCRAFT/3 WIRE SENDER:

- 1) MOVE THE DRIVE/TAB ALL THE WAY DOWN.
- 2) BOTH SENDERS MUST BE WIRED AND THE BOTTOM LIGHT ON BOTH SIDES MUST BE LIT. IF ONLY ONE SENDER IS BEING USED, WIRE BOTH SIDES OF THE DASH PANEL TO THE SINGLE SENDER.
- 3) ADJUST THE MERCURY SENDER SO THE BOTTOM LIGHT IS ON. WHEN TIGHTENING THE BOLTS, THE LIGHT MIGHT TURN OFF OR SHOW TWO LIGHTS. IF SO, LOOSEN BOLTS, ADJUST SENDER AND TIGHTEN BOLTS AGAIN. SENDER IS VERY SENSITIVE TO MOVEMENT.
- 4) MOVE THE DRIVE/TAB ALL THE WAY UP.
- 5) USING 1/16 ALLEN KEY, REMOVE THE BACK COVER.
- 6) USING A SMALL FLAT SCREWDRIVER, **CAREFULLY** TURN THE ADJUSTMENT SCREW ON THE BACK OFF THE LED PANEL ALL THE WAY COUNTERCLOCKWISE. SOME OF THE TOP LED'S SHOULD TURN OFF.
- 7) SLOWLY TURN THE ADJUSTING SCREW CLOCKWISE UNTIL THE THE TOP LED LIGHT BEGINS TO ILLUMINATE. PANEL IS NOW ADJUSTED FOR FULL RANGE. NOW ADJUST THE OTHER SIDE. CYCLE UP AND DOWN A FEW TIMES TO MAKE SURE LIGHTS ARE ADJUSTED PROPERLY.
- 8) REINSTALL REAR COVER.
- 9) 2 SLOT SHOWN. SAME INSTRUCTIONS FOR 4 AND 6 SLOT PANELS.

137-8684 HARNESS KIT COMES WITH:  
(2) 30' SENDER HARNESS (GREY, BLUE AND WHITE)  
(1) 30' RED WIRE  
(1) 5AMP FUSE AND HOLDER  
(20) BUTT CONNECTORS

