



Pressure, Level, Temperature and Trim Gauges

Operation:

Gauges operate by drawing a low electrical current from a variable resistance sender. As the sender resistance increases or decreases with pressure, level, temperature or tilt, the amount of current flowing increases or decreases proportionally causing the meter's pointer to deflect.

Troubleshooting:

Symptom recognition and visual inspection are the first steps to effective troubleshooting. Refer to your installation instructions to verify that the gauge is installed properly. **Note: senders must be grounded in order for gauges to function. In the case of pressure and temperature senders, this means no thread sealant can be used on the sender's threads. The threads on pressure and temperature senders are tapered and self-sealing.** Gauges usually exhibit two symptoms: inoperative or not reading correctly.

1. **Gauge is inoperative** – To test the gauge, disconnect the sender terminal. Turn the ignition switch on. The gauge pointer should be pegged fully to the left side of the gauge. If it doesn't, test to see if the ignition voltage is present by connecting a multimeter between the "I" and "G" terminals. If the voltage is not present (Approximately 12 volts DC for 12 volt systems, 24 volts DC for 24 volt systems) troubleshoot the wiring from the ignition and to ground. If the gauge pointer does peg to the left, short the sender terminal of the gauge to ground, the pointer should deflect fully to the right. If it does not, the gauge is faulty. If the pointer does peg to the right, and the ignition voltage is present, the problem is with the sender or the wiring from the sender to the gauge. **Note: If European senders are being used, pointer deflection will be the opposite of above on level and pressure gauges.**
2. **Gauge is reading incorrectly** – This problem usually occurs when the gauge and sender are not compatible. Make sure the sender is made for the specific range of your gauge (150 psi sender for 150 psi gauge, 100-240 F sender for a 100-240 F gauge, etc.). Unless otherwise specified, Hardin Marine will send gauges that are compatible with American made 240-33 ohm senders. European or AC senders will cause incorrect readings unless the gauge was manufactured to work with those senders.

Dual Station Gauges:

When running two gauges from one sender, the sender must be a dual station sender. A single gauge sender will not run two gauges correctly. The gauges must be the same, mixing gauges from different manufacturers may cause one gauge to read higher than the other gauge.

EAST COAST
11 INDUSTRY DRIVE
PALM COAST, FL 32137
P (877) 900-7278 | F (386) 445-1122

WEST COAST
5725 REDWOOD DRIVE
ROHNERT PARK, CA 94928
P (707) 585-9006 | F (707) 585-2935

Wiring Connections For Electrical Gauges

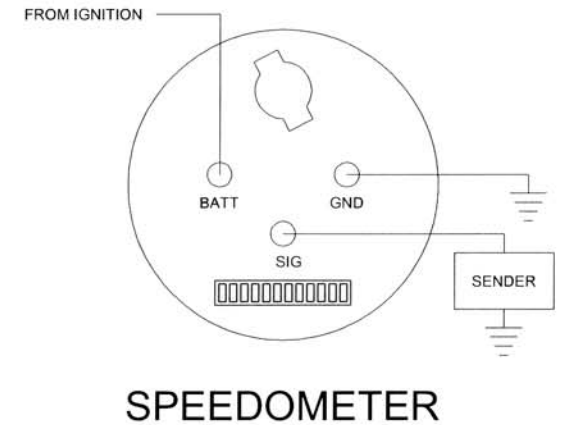
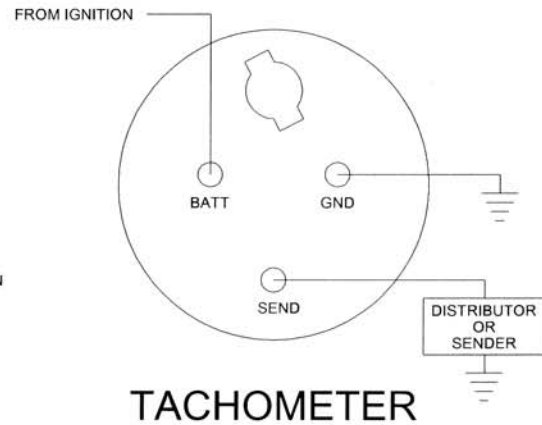
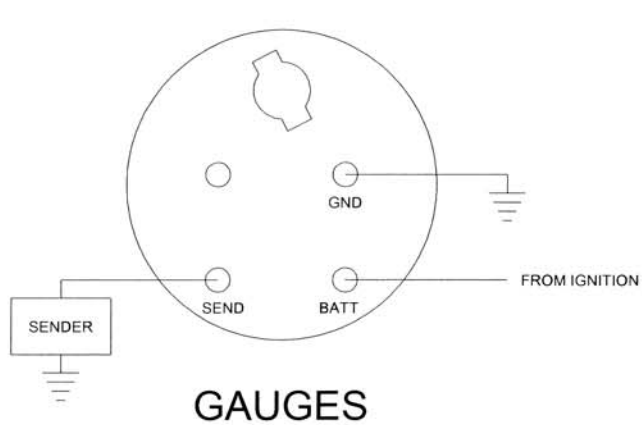
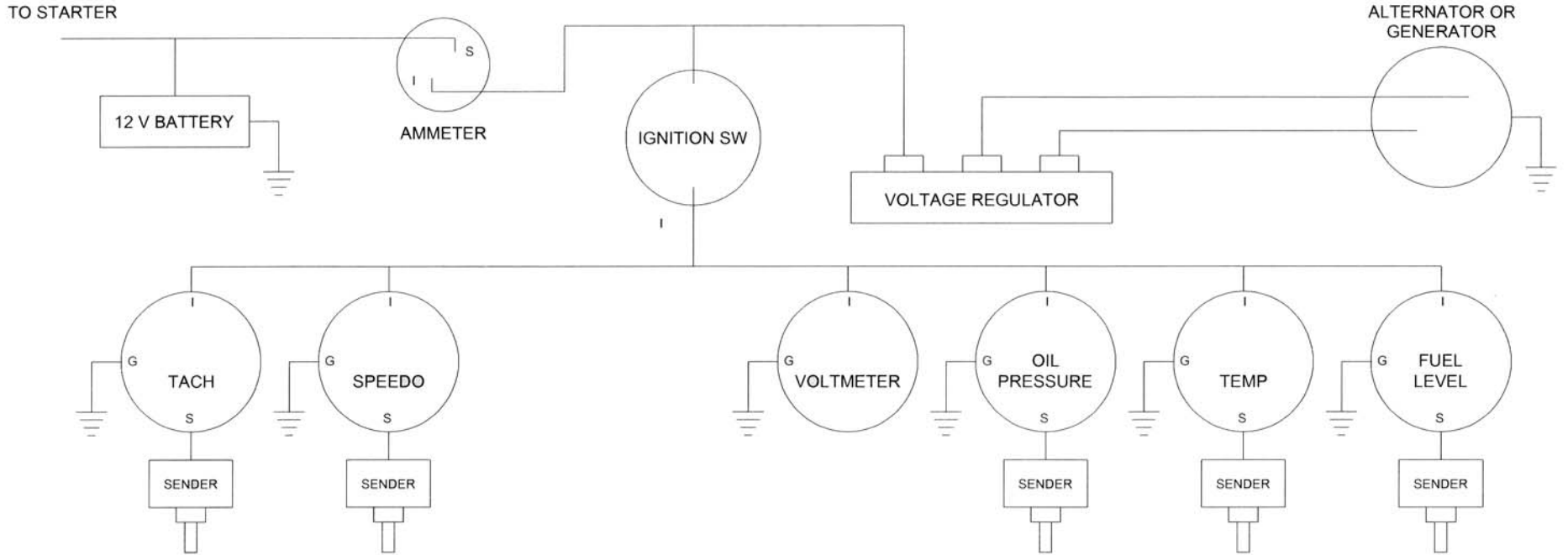

2" Series 2000 Air-Core Gauge Installation Instructions

WARNING

Improper installation may damage the instrument and/or cause injury to the installer. If you have installation questions, please contact the factory. Disconnect battery cable before installing the instrument. Check for obstructions behind dash panel such as wires and hoses before cutting the mounting hole for the instrument.

MOUNTING

Recommended dash hole size: 2.125 +/- .015 in DIA.
 Secure the instrument into dashboard with mounting "U" clamp, lock washers and hex nuts. If dashboard thickness exceeds clamp grip range, clamp legs may be shortened.
 Position instrument in dashboard prior to tightening clamp nuts to recommended torque.
 Maximum recommended tightening torque for all hardware: 6 lb-in.
 Caution, over tightening mounting hardware may damage the instrument.

MAINTENANCE

Periodically check and torque all hardware per mounting specifications.
 Clean electrical connections if corrosion develops around hardware.
 Clean glass with a soft, damp, clean cloth.

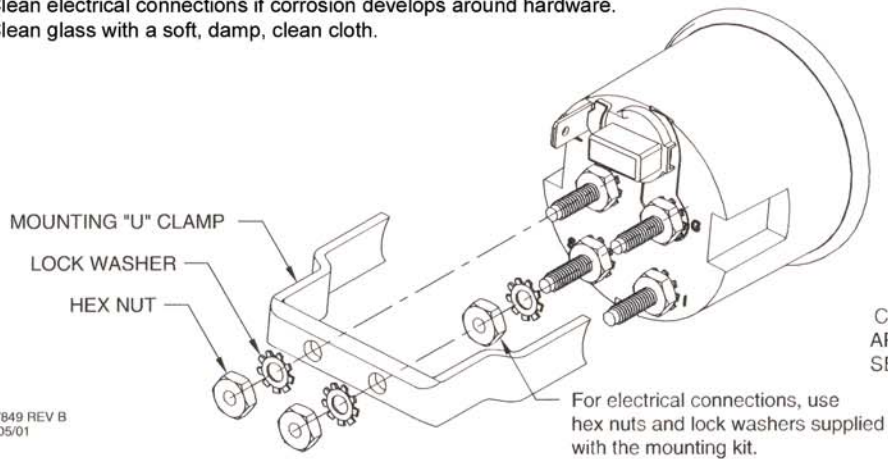

TO STARTER SOLENOID

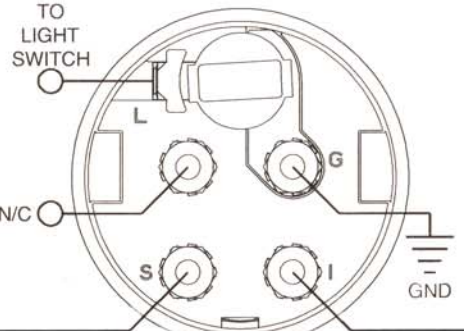
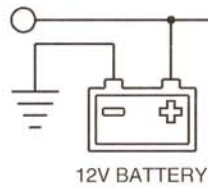

AMMETER
(REAR VIEW)

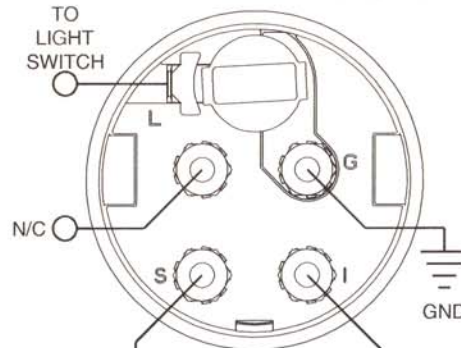

CONNECT TO APPROPRIATE SENDER TYPE

SENDER

STANDARD GAUGE
(REAR VIEW)

VOLTAGE REGULATOR

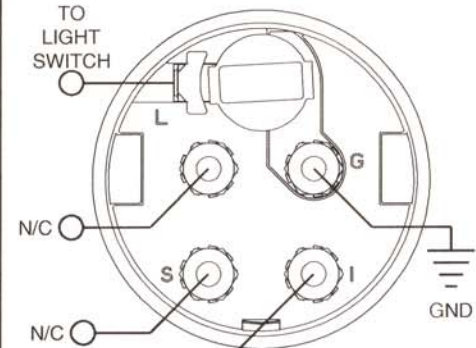
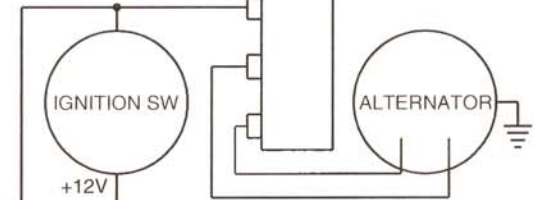

VOLTMETER
(REAR VIEW)

NOTE: A N/C MEANS NO CONNECTION TO THE STUD. SEE INSTALLATION WARNING NOTE.

3" Model 3-12 Tachometer Installation Instructions

⚠ WARNING

Improper installation may damage the instrument and/or cause injury to the installer. If you have installation questions, please contact the factory.
 Disconnect battery cables before installing the instrument.
 Check for obstructions behind dash panel such as wires and hoses before cutting the mounting hole for the instrument.

MOUNTING

Recommended dash hole size: 3.380±.015 in (85.85±0.38 mm) DIA.
 Secure the instrument into dashboard with mounting "U" clamp, lock washers and hex nuts.
 If dashboard thickness exceeds clamp grip range, clamp legs may be shortened.
 Position instrument in dash board prior to tightening clamp nuts to recommended torque.
 Maximum recommended tightening torque for all hardware: 6 lb-in (0.68 N-m).
 Caution, over tightening mounting hardware may damage the instrument.

MAINTENANCE

Periodically check and torque all hardware per mounting specifications.
 Clean electrical connections if corrosion develops around hardware.
 Clean glass with a soft, damp, clean cloth.

