



Thank you for purchasing the 496 HO and Mag E-Top Performance Package!

The relocation kit components in this package are designed to cover the many variations for both, the 496 HO and Mag series. In many cases, brackets and components in the relocation kit may not be required or may need to be positioned differently than illustrated in the instruction manual to work in your specific model year application.

It is Custom Marine's intent to supply everything necessary to make the installation as easy as possible. The relocation kit contains the parts needed to overcome most obstructions.

Custom Marine is constantly seeking ways to improve our products to better serve you, our customer. Therefore, as new model year discrepancies emerge we will continue making adjustment to the package.

Please let us know if you encounter any issues during installation.

Thank you again for your patronage.



496 HO / MAG

E-Top PERFORMANCE PACKAGE

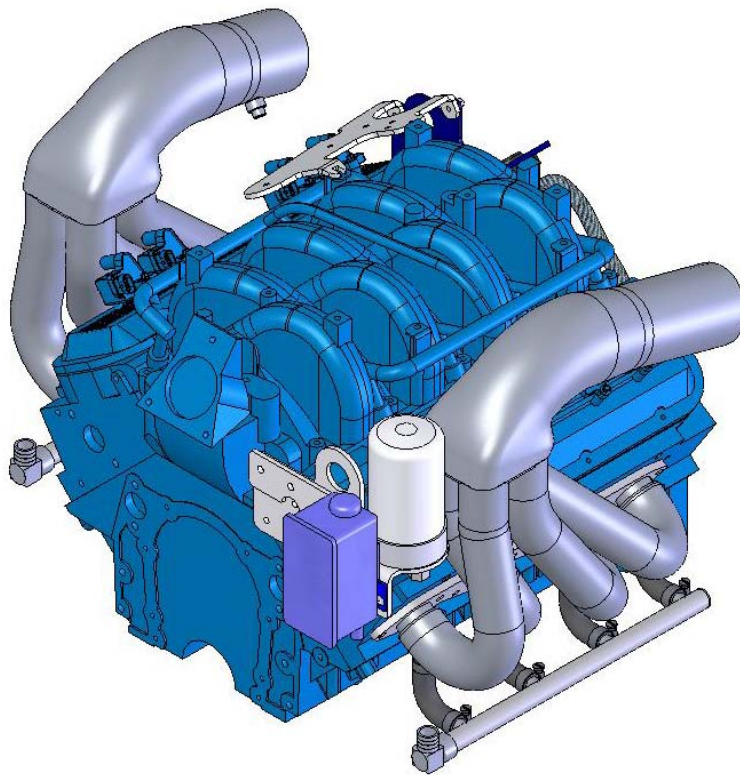

496 HO / MAG RELOCATION KIT

TABLE OF CONTENTS

OVERVIEW OF PARTS SUPPLIED BY CMI	PAGE....4
496 HO COMPONENTS INDEX	PAGE....5
STEP BY STEP COMPONENT REMOVAL AND INSTALLATION	PAGE....6
SHIFTER PLATE ILLUSTRATION	PAGE....7
OIL FILTER COMPONENTS & ECU BRACKET MOD.	PAGES..8-9
REMOTE OIL FILTER ASSEMBLY	PAGE...10
HEADER, INTAKE MANIFOLD COVER, AND HEAT SENSOR INSTALLATION	PAGES..11-12

CMI Supplied Parts Overview - Illustration A1



ITEM NO.	Qty.	Part Number	DESCRIPTION
1	1	28965	SHIFTER BRACKET
2	1	28954	OIL FILTER BRACKET
3	1	50921	OIL FILTER SPIN-ON
4	8	32030	HOSE JUMPER - .75 X 90 DEGREE
5	2	30140	DISTRIBUTION TUBE ASSY
6	16	36000	HOSE CLAMP #8
7	2	19580	ELBOW, 1 X 3/4 IPT, HHT16
8	2	M6 x 1 x 12mm	HEX FLG SCREW METRIC
9	2	M6 x 1.25 x 12mm	HEX FLG SCREW METRIC
10	2	38206	5/16-18 X 0.625 LG HEX HEAD
11	1	13175 PORT	496 E-TOP
12	1	13175 STD	496 E-TOP
13	1	32248	SE 496 OILLINE ASSEMBLY

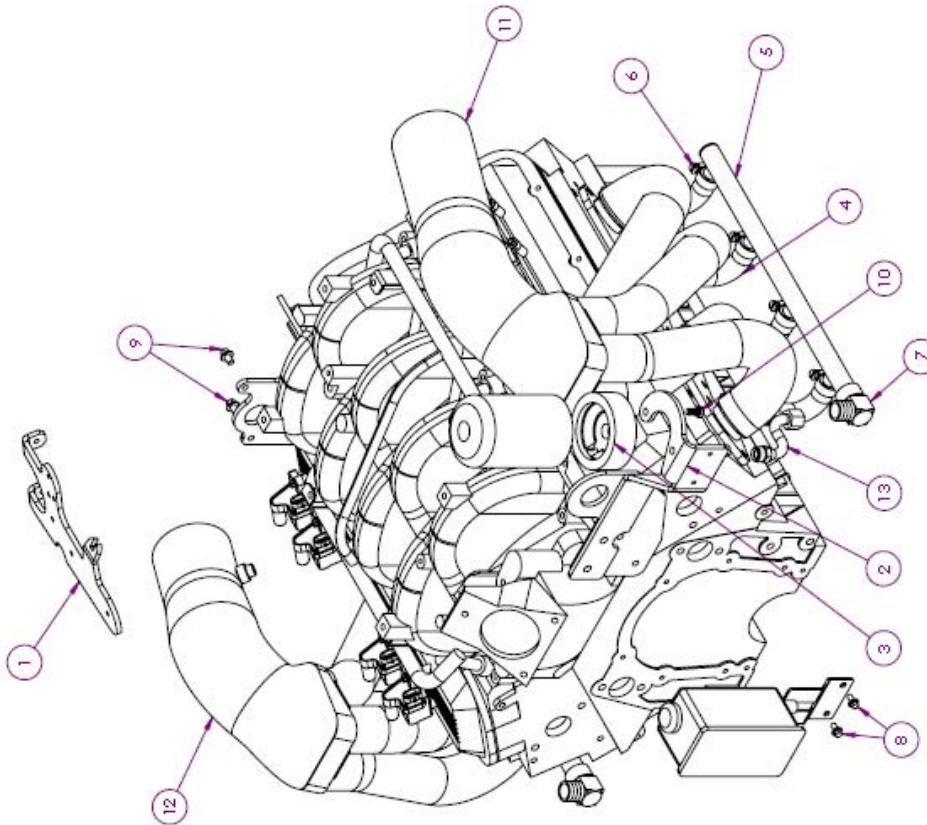

496 E-Top Performance Package

Component Index

Port Side Header & Assembly Components in each Box

- (1) Port Side 496 E-Top Header
- (1) (19890) Heat Sensor Bungs Installed in the Headers
- (1) (34160) Head Gaskets
- (8) (38490) Metric Header Bolts
- (1) (30140) Stainless Steel Distribution Tubes

Kit Number 41016

- (4) (32030) 3/4" I.D. X 90 degree Hose for Distribution Tubes
- (8) (36020) #8 Hose Clamps
- (1) (36090) #12 Hose Clamps
- (1) (19580) .75 NPT X 1 X 90 Degree Fitting
- (1) (19650) .75 NPT X 1 X Straight Fitting

Starboard Side Header & Assembly Components in each Box

- (1) Starboard 496 E-Top Header
- (1) (19890) Heat Sensor Bungs Installed in the Headers
- (1) (34160) Head Gaskets
- (8) (38490) Metric Header Bolts
- (1) (30140) Stainless Steel Distribution Tubes
- (4) (32030) 3/4" I.D. X 90 degree Hose for Distribution Tubes

Kit Number 41016

- (8) (36020) #8 Hose Clamps
- (1) (36090) #12 Hose Clamps
- (1) (19580) .75 NPT X 1 X 90 Degree Fitting
- (1) (19650) .75 NPT X 1 X Straight Fitting

496 Components Kit 41043

QTY	PART #	DESCRIPTION	MATERIAL
(1)	(28965)	Shifter Bracket	1/4" HRPO / Coated Black
(1)	(28954)	Oil Filter Bracket	1/4" HRPO / Coated Black
(1)	(50921)	Oil Filter Spin-On	Aluminum
(3)	(29980)	Offset Spacer	.50 X .25 Wall CRS Tube 2.625 lg.
(2)	(19892)	3/4" Hose Plugs	3/4" X 3/4" Stainless Steel, Round
(1)	(32248)	Oil Hose Extension	Stainless Steel with Brass Fitting

496 Hardware Components Kit 41044 (Located in the relocation kit box)

QTY	PART #	DESCRIPTION	MATERIAL
(2)	(38206)	5/16" – 18 X 5/8" Flange Bolt	Carbon Steel
(3)	(38207)	M6 – 1.00 X 10 Flange Bolt	Carbon Steel
(2)	(38208)	M6 – 1.00 Flange Nut	Carbon Steel
(1)	(38209)	M6 – 1.00 X 12 Flange Bolt	Carbon Steel
(3)	(38211)	M6 – 1.00 X 130 SHCS	Zink Plated Carbon
(1)	(38212)	1/4" X 1/2" Roll Pin	Stainless Steel (Assembles into Shifter Bracket)
(2)	(36090)	#12 Hose Clamps	Stainless Steel
(1)		Assembly Instruction Packet	White Paper Envelope
(1)		Stock ECU Modification Template	11 x 17 Paper

STEP BY STEP COMPONENT REMOVAL AND INSTALLATION

STEP 1) REMOVE ENGINE COVER.

STEP 2) REMOVE (2) COOLANT HOSES FROM BOTTOM OF LOG MANIFOLD. PLUG LOWER HOSE AND CLAMP AS SHOWN IN PICTURE 1.



Picture 1

STEP 3) REMOVE (1) SHIFT BRACKET BOLT FROM TOP OF LOG MANIFOLD ON STARBOARD SIDE.

STEP 4) **IMPORTANT!** REMOVE HEAT SENSORS ON BOTH MANIFOLDS FIRST, REMOVE (8) LOG MANIFOLD BOLTS. REMOVE LOG MANIFOLD, WHILE BEING CAREFUL NOT TO BREAK SPARK PLUGS OR RUBBER BOOTS. CLEAN GASKET SURFACE ON MOTOR.

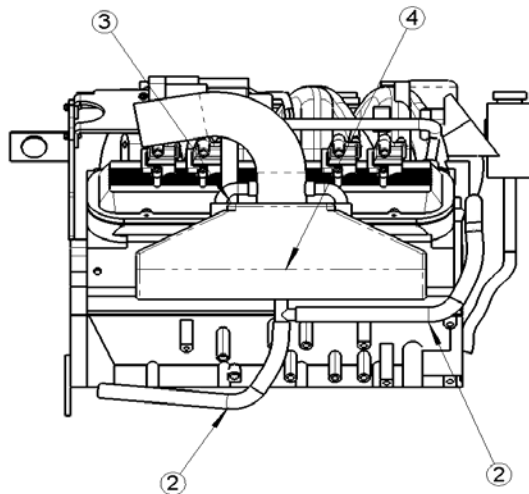

STEP 5) REMOVE SHIFTER BRACKET MOUNTING BOLTS. **DO NOT** REMOVE SHIFT CABLE OR WIRE HARNESS CONNECTOR. BE CAREFUL NOT TO DROP SPACERS. REMOVE BRACKET.

STEP 6) REMOVE (2) SHIFT PLATE MOUNTING BOLTS FROM BRACKET ON REAR OF ENGINE. AND REMOVE BRACKET.

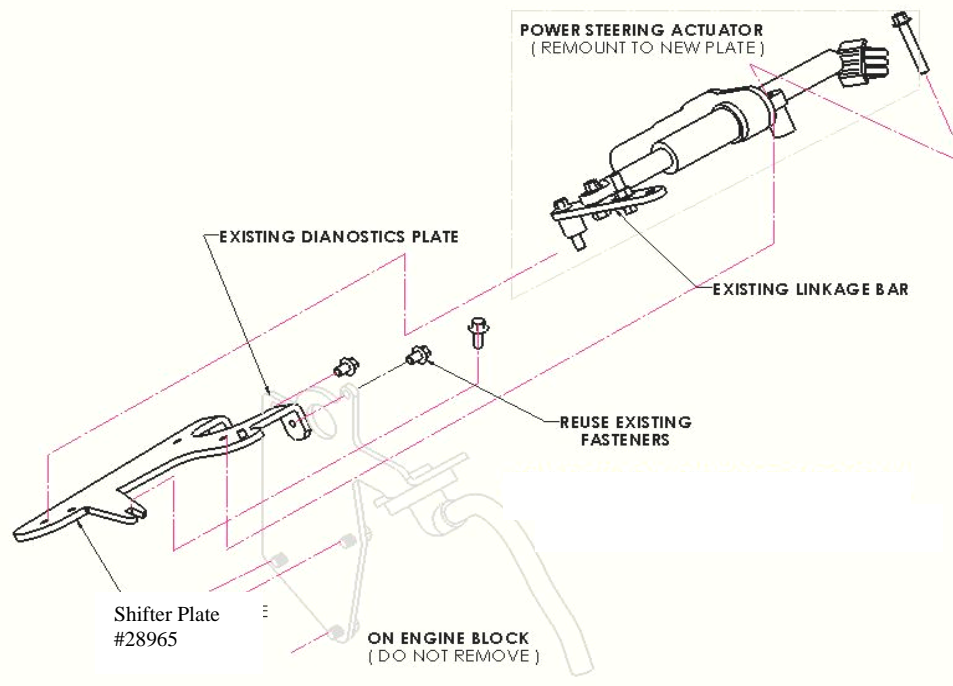
SHIFTER PLATE - ILLUSTRATION A-2

STEP 7) INSTALL CMI SHIFT PLATE REUSING REAR MOUNTING BOLTS. USE SUPPLIED SHOULDER NUT TO MOUNT TO STUD ON INTAKE MANIFOLD. REMOUNT SHIFT BRACKET WITH ATTACHED CABLES, REUSING SAME HARDWARE AS WAS USED ON STOCK SHIFT PLATE. MOUNT AS SHOWN IN PICTURE 2.

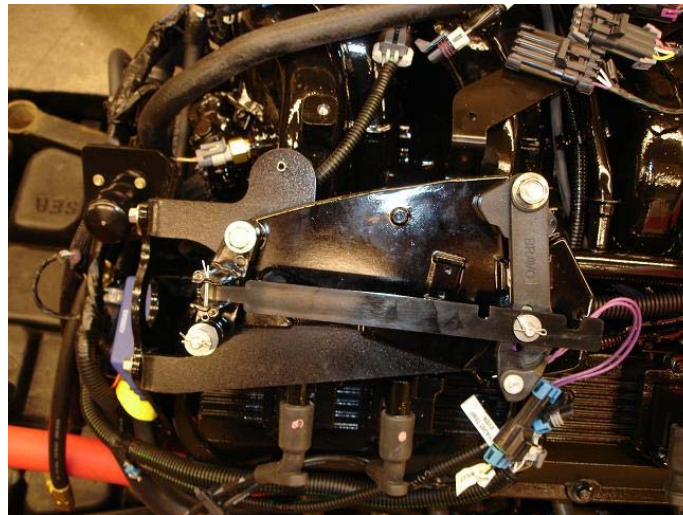

Picture 2

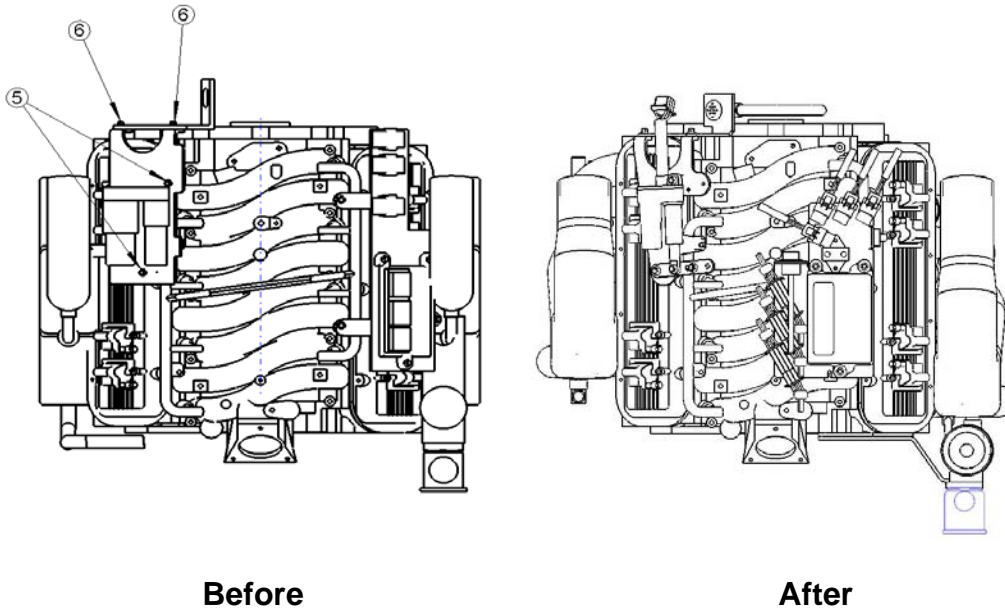

REMOTE OIL FILTER COMPONENTS & ECU BRACKET MODIFICATION
- PORT SIDE -

STEP 8) REMOVE (3) RESERVOIR BRACKET BOLTS & REMOVE FORK BRACKET & "T" STRAP. FORK BRACKET WILL BE REUSED. AS SHOWN IN PICTURE 3.



Picture 3

STEP 9) DISCONNECT OIL FILTER LINES AT FILTER HOUSING. USE CONTAINER TO CAPTURE OIL.

STEP 10) REMOVE (4) NUTS FROM STUDS THAT SECURE ECU BRACKET TO INTAKE & EXHAUST MANIFOLD.

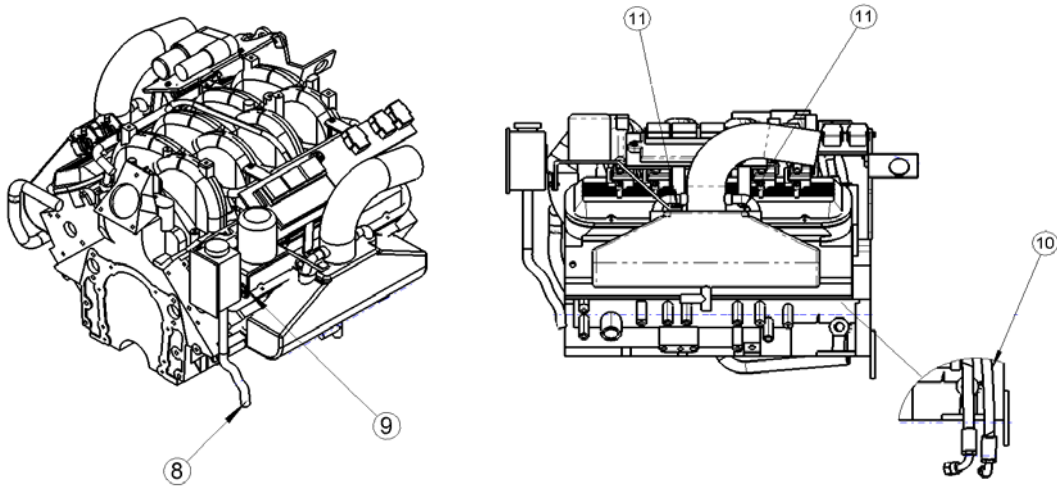

STEP 11) LIFT BRACKET FROM STUDS TO PROVIDE FOR LOG MANIFOLD REMOVAL.

STEP 12) REMOVE (2) COOLANT HOSES FROM BOTTOM OF LOG MANIFOLD AND PLUG LOWER LINE AS SHOWN IN PICTURE 1. REMOVE (8) LOG MANIFOLD ATTACHING BOLTS. REMOVE LOG MANIFOLD BEING CAREFUL NOT TO BREAK SPARK PLUGS OR WIRE BOOTS.

STEP 13) MODIFY STOCK ECU BRACKET WITH SUPPLIED TEMPLATE.

REMOTE OIL FILTER ASSEMBLY

- STEP 14)** RE-USE OLD O-RING AND FITTING. LUBRICATE FLAT “O” RING WITH MOTOR OIL, AND INSTALL IN RECESSED AREA IN OIL FILTER ADAPTOR WITH THREADED LINE FITTING AS SHOWN. **IMPORTANT!** FLAT “O” RING MUST BE PROPERLY SEATED IN OIL FILTER HOUSING TO PREVENT LEAKS. INSPECT TO ENSURE ALL HOSES ARE PROPERLY SEATED
- STEP 15)** MOUNT OIL FILTER HOUSING TO BRACKET WITH (2) PROVIDED BOLTS. MOUNT THE CLIP BRACKET TO MAIN BRACKET USING THE (2) SCREWS REMOVED FROM THE ORIGINAL. INSTALL OIL LINE EXTENSION TO THE OIL FILTER ADAPTOR. SEE PICTURE 4.

OIL FILTER BRACKET – ILLUSTRATION A-1

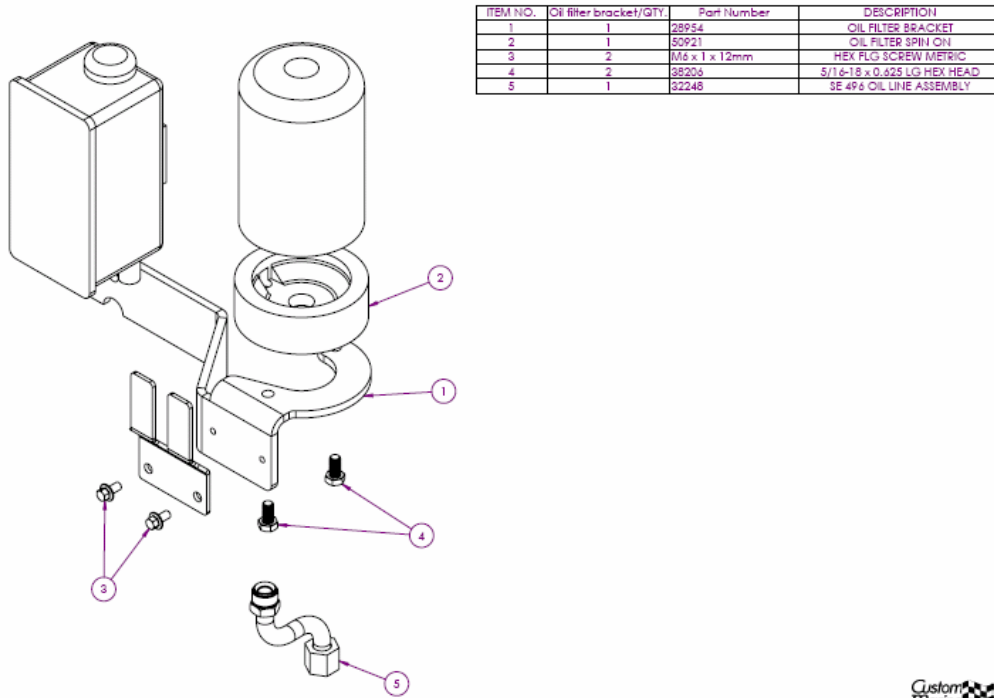

Custom
Marine



Picture 4

STEP 16) REMOVE AIR CONTROL BRACKET BY REMOVING (2) NYLOCK NUTS FROM STUDS ON FRONT OF ENGINE. INSTALL REMOTE OIL FILTER BRACKET ON THESE STUDS, FOLLOWED BY THE AIR CONTROL BRACKET & (2) NYLOCK NUTS. SEE PICTURE 5



Picture 5

STEP 17) REINSTALL RESERVOIR ON FORK BRACKET & REATTACH HOSE AT BOTTOM.

STEP 18) INSTALL CMI HEADERS PER MERCURY RACING SERVICE MANUAL PROTOCOL. ADJUST LENGTH OF COOLING HOSES TO FIT DISTRIBUTION TUBE ON HEADERS. SEE PICTURES 6 AND 7 FOR HEADER INSTALL REFERENCE.

STEP 19) INSTALL INTAKE MANIFOLD COVER USING (3) SPACERS & LONGER SCREWS PROVIDED.

STEP 20) INSTALL HEAT SENSORS (2) IN HEADER COLLECTOR BUNG.

STEP 21) ATTACH HEADER WITH CUSTOMER SUPPLIED HOSE AND CLAMPS TO TRANSOM TIPS OR DIVERTER.

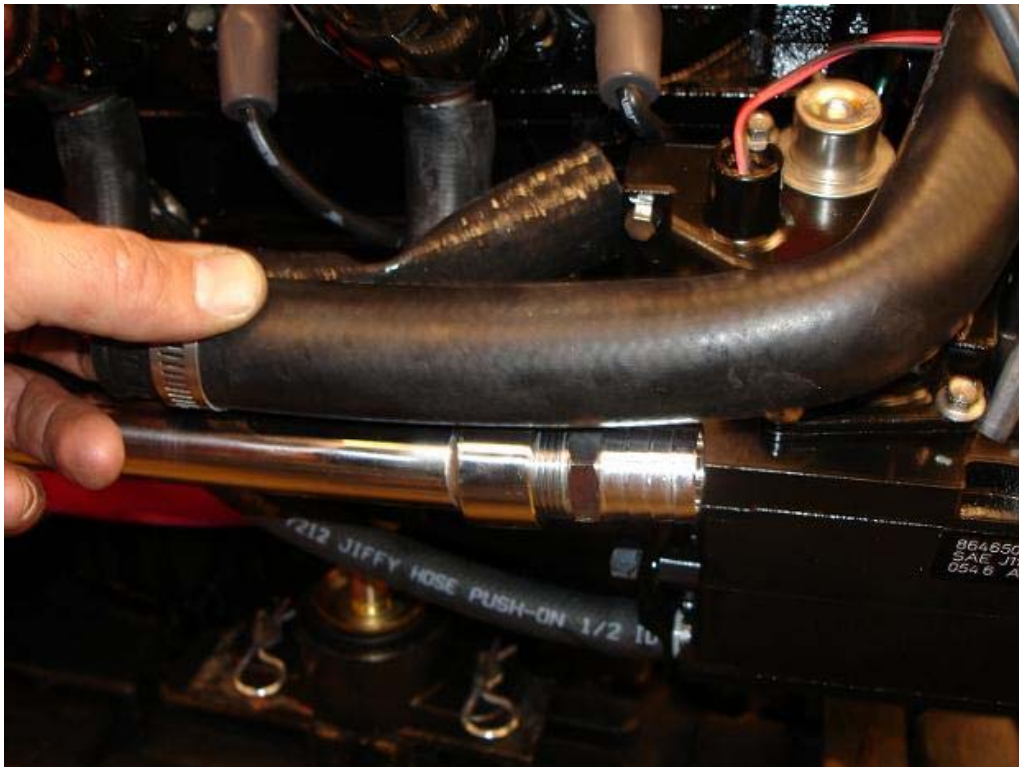

Picture 6



Picture 7

IMPORTANT!

**START ENGINE AND CHECK ALL
HOSE CONNECTIONS FOR
POSSIBLE LEAKS BEFORE USING.**

IMPORTANT!

FIRST RUN FOR 10 MINUTES.

ALLOW ENGINE TO COOL.

CHECK HEADER BOLTS FOR

TIGHTNESS.