

TITLE:  
2 STAGE SEA PUMP FOR MERCURY  
525,600,662 & 700

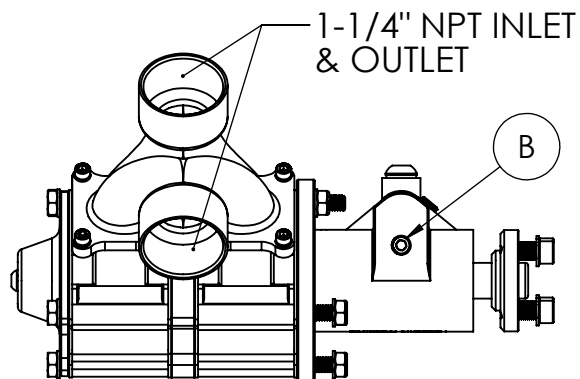
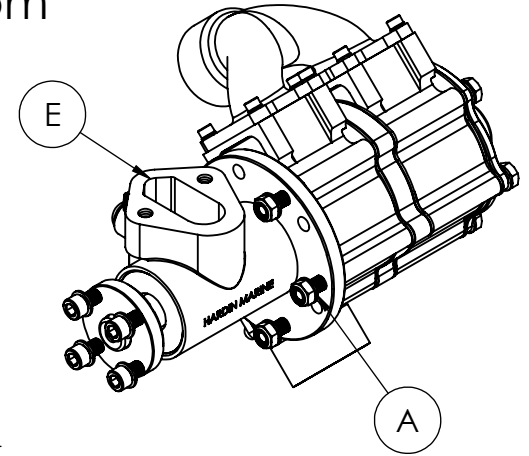
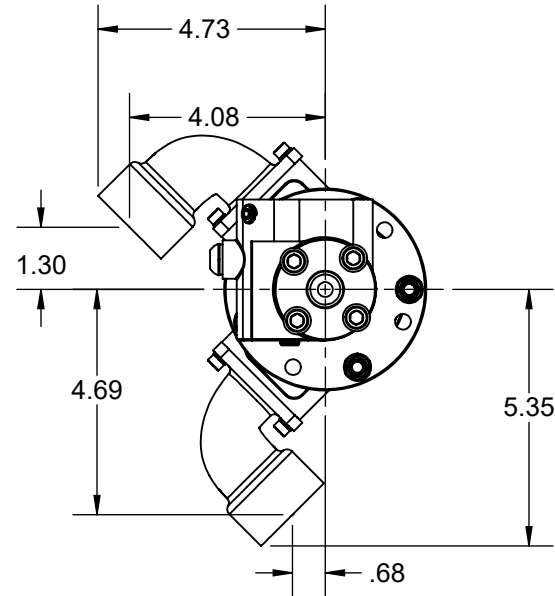
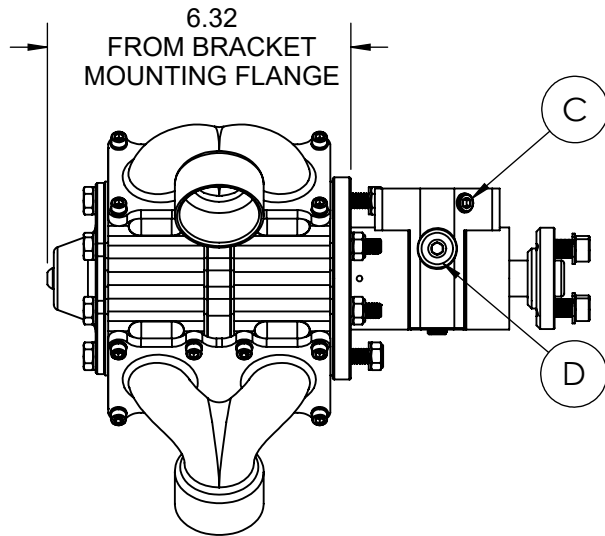

Installation Instructions:

- 1) Install pump on to the factory bracket using the 3 bolts shown in Fig. A. Torque nuts to 20 foot lbs..
- 2) Apply liquid pipe thread sealer to the supplied 1/8 npt pipe plugs.
- 3) Install 1 pipe plug into the bottom of the housing, Fig. B. This is your oil drain.
- 4) If you are not using optional 625-4221 vent equalizer, install pipe plug into the side of the housing, Fig. C.
- 5) Use 7/32 allen key to remove the side oil fill hole bolt and washer, Fig. D.
- 6) Fill housing, Fig. E, with Quicksilver High Performance Gear Lube until the oil starts coming out Fig. E threaded hole. Reinstall bolt and washer. Torque to 80 inch lbs..
- 7) Install fuel pump, not shown.
- 8) Install sea pump pulley. Apply blue loctite to threads and torque to 20 foot lbs.
- 9) Only use liquid pipe thread sealer to install inlet and outlet fittings.

TITLE:  
GEN 5/6 VENT EQUALIZER

[www.hardin-marine.com](http://www.hardin-marine.com)

THIS KIT IS DESIGNED TO ALLOW VENTING OF PRESSURE BUILD UP INSIDE THE SEAPUMP HOUSING THAT COULD CREATE PREMATURE FAILURE TO BE RELEASED THROUGH THE EXISTING FUEL PUMP VENT SYSTEM.

Note will work with all sea pumps listed below that the front housing has been tapped for 1/8 npt:

625-4112

625-4118

625-4176

625-4219

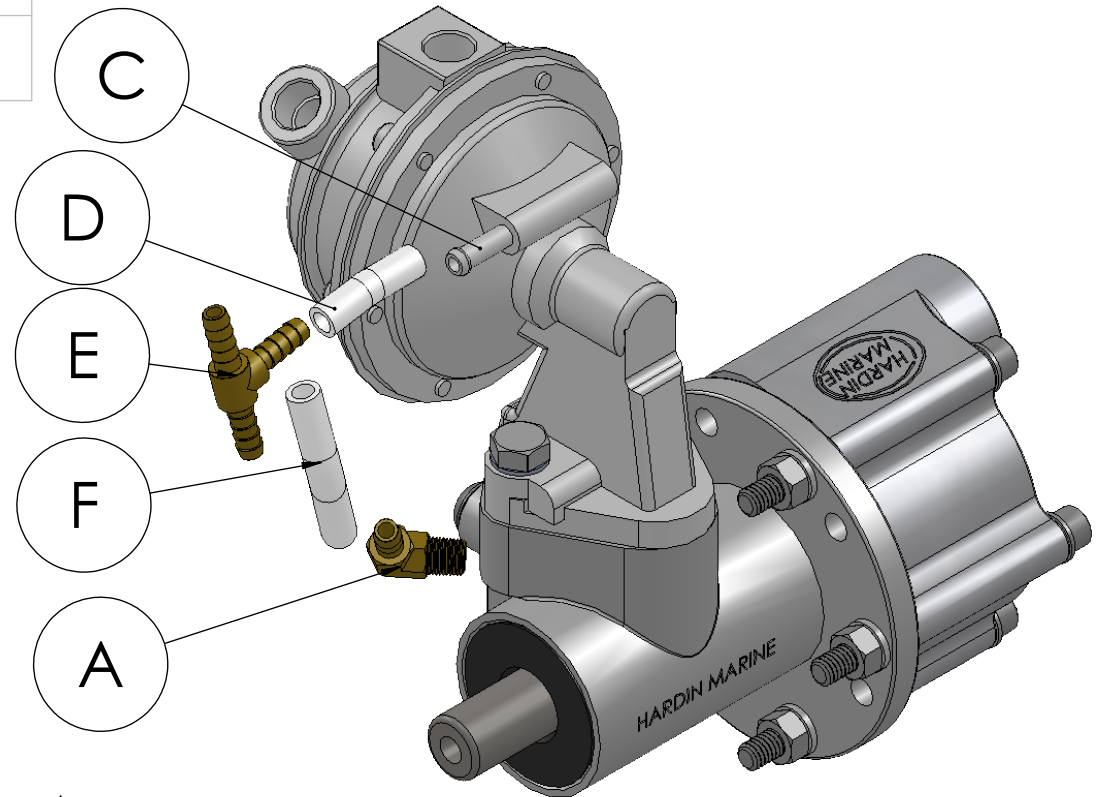

Install Instructions:

- 1) Apply liquid pipe tape to 625-4222 fitting, Fig. A.
- 2) Install into the threaded port just below the sea pump mounting flange, Fig. B.
- 3) Remove your existing hose from the burst vent barb, Fig. C.
- 4) Cut the supplied 625-4224 hose, Fig. D, to connect 625-4223 tee, Fig E to the burst vent barb.
- 5) Cut hose, Fig. F, to connect bottom fitting to the tee.
- 6) Reconnect the existing hose going to the flame arrestor to the tee. Kit is supplied with enough hose in case you want to replace the existing hose.
- 7) Install wire ties on all hose barb connections.

